

STEP 1 - ROTARION CAM Kit

HOW TO REMOVE ROTARION STAINLESS STEEL HANDLES

1.- Remove (unscrew) the Click-Lock clamps including all extenders/spacers, and without removing the four black color thread adapters Part# 4.1 "SC-to-T2".

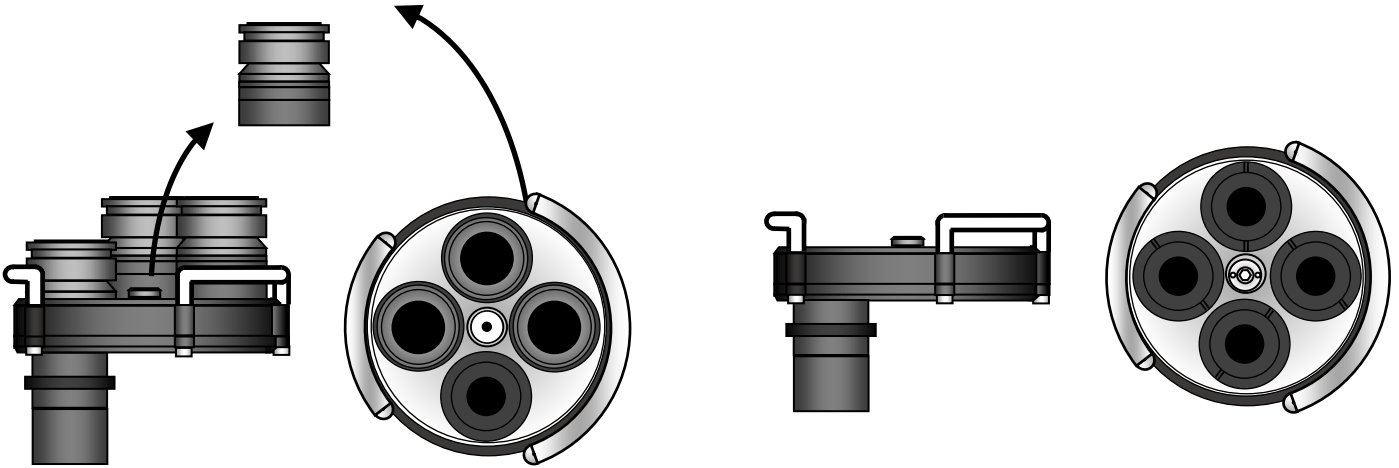

2.- Unscrew the 2 screws (A) located on the bottom of the ROTARION with the included Allen wrench and remove the SMALL handle (B) carefully.

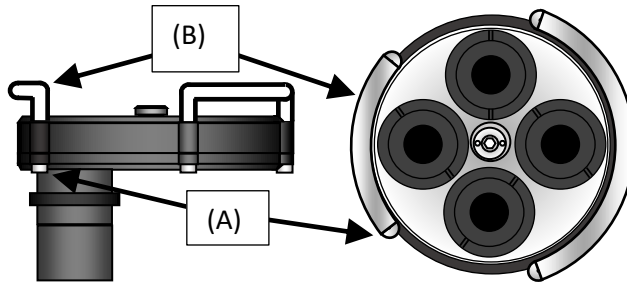

3.- Introduce the NEW 2 stainless steel Allen screws (C) and screw the 2 Nylon head nuts (D) using the supplied Allen wrench and the N° 10 wrench. Screw the 2 nuts tightly.

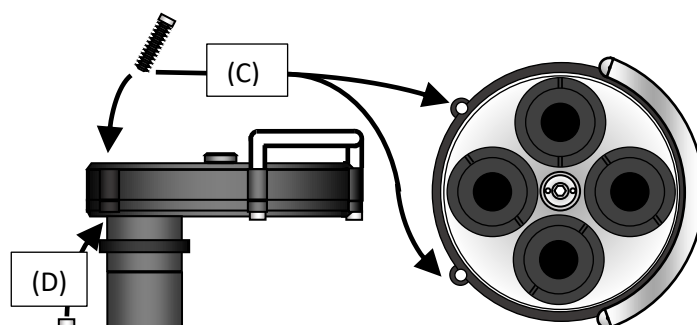

4.- Unscrew the 3 screws (E) located on the bottom of the ROTARION with the included Allen wrench and remove the LARGE handle (F) carefully.

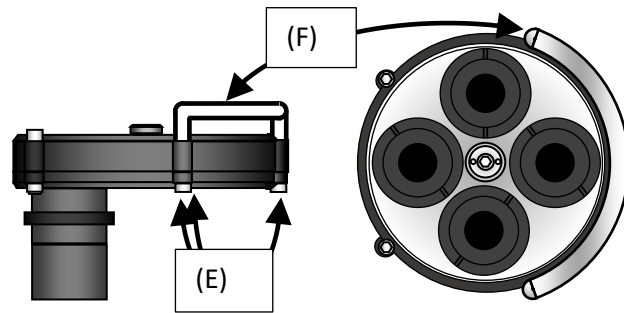

5.- Introduce the NEW 3 stainless steel Allen screws (G) and screw the 2 Nylon head nuts (H) using the supplied Allen wrench and the N° 10 wrench. Screw the 3 nuts tightly.

